

ACE Series

Flowell Pneumatics Pvt. Ltd. Product Catalogue

Welcome to Flowell Pneumatics, Your Trusted Partner
In Compressed Air Piping Solutions.



CERTIFICATIONS



PRESSURE RATING TESTED BY ARAI

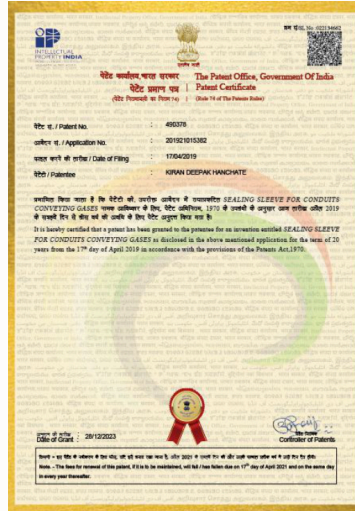

PATENT



ISO 9001:2015



FIRE RESISTANT

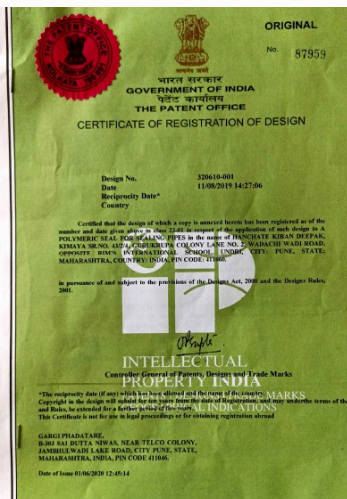

DESIGN REGISTRATION



CE CONFORMITY



FPPL Products Meet The Requirements of ASME B31.3 Standard



10 Years Warranty For GEM / ACE / ACE+ Ranges

FLOWELL PNEUMATICS PVT. LTD.



Flowell Pneumatics Pvt. Ltd. offers a comprehensive compressed air piping solution that ensures superior operational efficiency and suitability for a wide range of industrial applications, all at competitive prices.

Our piping system stands out with its reliability, durability, and rigidity, providing a corrosion-free, modular design that meets the highest industrial standards. With a 10-year warranty, Flowell guarantees long-lasting performance.

The solid metal construction of our piping system is designed for ease of installation, making it an ideal solution for compressed air, vacuum, and inert gas distribution. It supports operating pressures up to 16 bar and -0.87 bar in a temperature range of -20°C to 75°C .

The extruded aluminium pipe (6063-T6) and SS-304/316L seamless pipes feature a smooth interior surface that reduces friction, minimizes pressure loss, and ensures laminar flow. With full-bore fittings and leak-free connections, our system prevents air wastage and maximizes efficiency.

Flowell Pneumatics introduces three advanced ranges of compressed air and inert gas piping systems:

GEM – Aluminum pipes with SS 304 fittings for general industrial applications.

ACE – SS 316 pipes with SS 316 fittings for food and beverage industries.

ACE Plus – SS 316+ pipes and fittings designed specifically for pharmaceutical applications.

Flowell's solutions deliver the perfect balance of strength, simplicity, and performance for your industry needs.

OUR SERVICES



We specialize in customising and installing aluminium and stainless steel piping systems for diverse industries. Our services include pipe fittings, turnkey solutions, integration with global brands, and advanced monitoring systems for optimal performance.

01

Aluminum Piping Systems

For general industries.

02

Design & Installation

Tailored piping solutions

03

SS 304 Piping Systems

For food and beverage

04

SS 316L Piping Systems

Pharmaceutical applications

05

Compatibility

Works with global brands

06

Pipe Fittings

GEM Series, ACE Series, ACE Plus Series

07

Turnkey Solutions

Complete system packages.

08

Monitoring Systems

Flowmeters and dew-point meters.

WHY CHOOSE US?

Choosing Flowell Pneumatics is a smart decision because, with our extensive experience in compressed air piping and fittings, we provide innovative solutions that enhance efficiency and reliability. Our products simplify operations and contribute to the success of industries across the nation.



Unmatched Quality

Our aluminium air pipes offer superior quality, performance, and durability.



Expert Consultation

Our expert team helps you choose the perfect piping system for your needs.



Product Range

We provide aluminum pipes, steel systems, and fittings for industrial use.



Tailored Solutions

Efficient and reliable compressed air piping systems.



Timely Delivery

On-time delivery of all products to ensure your projects stay on schedule.

FOOD AND BEVERAGE APPLICATION



AEROSPACE

BEVERAGE

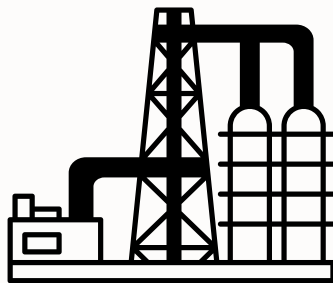
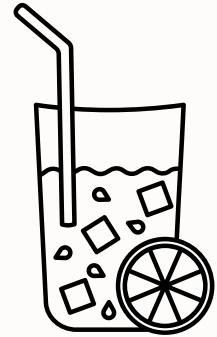

OIL & GAS

CHEMICAL

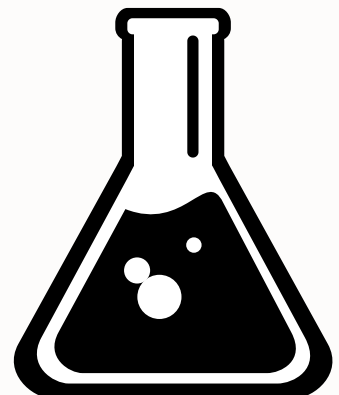

SS 304 COMPRESSED AIR PIPING FOR FOOD AND BEVERAGE APPLICATION

NPS	½"	1"	1 ½"	2"	2 ½"	3"	4"
Size	φ21	φ33	φ48	φ60	φ73	φ90	φ114



TECHNICAL CHARACTERISTICS FOR ACE SERIES

- **Diameters (in mm)**

21-33-48-60-73-90-114

- **Max working temp**

-20°C to 75°C

- **Max working pressure**

16 bar : For sizes 21, 33, 48, 60

13 bar : For sizes 73, 90, 114

- **Vacuum level**

-0.87 bar

- **Pipe material**

SS 304 ERW/Seamless Pipes, Conforming to EN 10217-7, EN 10216-1

- **Pipe fittings material**

SS 304

- **Sealing material**

NBR / Silicone

- **Standard**

FLOWELL ACE Series products meet the requirements of ASME B31.3

- **Standard Finish of Pipe**

For Air - Matte Finish

For GAS - Matte Finish with respective standard gas colour radium lining

- **Compatibility**

Compatible with all Compressor oil / Oil free compressed air, Industrial vacuum, Nitrogen and Inert gases.

ACE SERIES CLAMP FIT RANGE



SS 304 - Seamless Pipe

FPP-4-21-5.7 / 33-5.7 / 48-5.7 / 60-5.7 / 73-5.7 / 90-5.7 / 114-5.7



Coupling-SS 304

FPC-4-21 / 33 / 48 / 60 / 73 / 90 / 114



Bend – SS 304

FPBC-4-21 / 33



Elbow – SS 304

FPEC-4-48 / 60 / 73 / 90 / 114

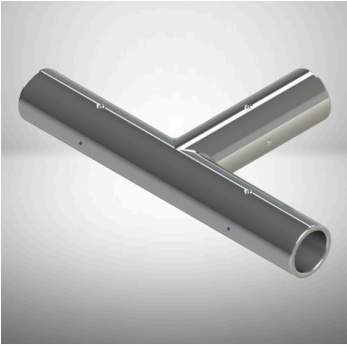

Tee – SS 304

FPTC-4-33 / 48 / 60
/ 73 / 90 / 114

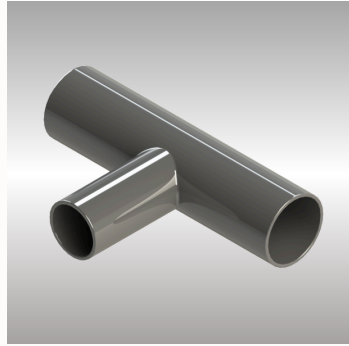

**Reducing Tee –
SS 304**

FPRTC-4-114X90 /
90X73 / 73X60 /
60X48



**End Cap – SS
304**

FPECC-4-21 / 33 / 48
/ 60 / 73 / 90 / 114

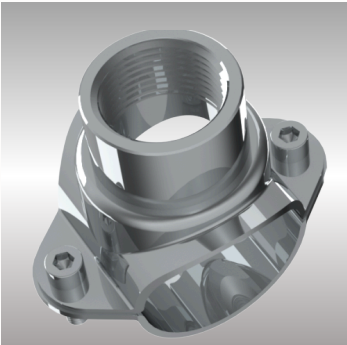

**Saddle Branch
– SS 304**

FPSB-4-33X21
48X33 / 60X33
73X48 / 90X60
114X73

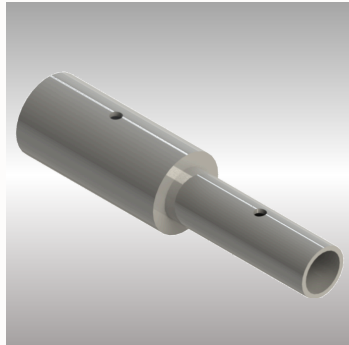

**Line Reducer –
SS 304**

FPLRC-4-33X21
48X33 / 60X48
60X33 / 73X60
73X48 / 90X73
90X60 / 90X48
114X90 / 114X73
114X60 / 114X48

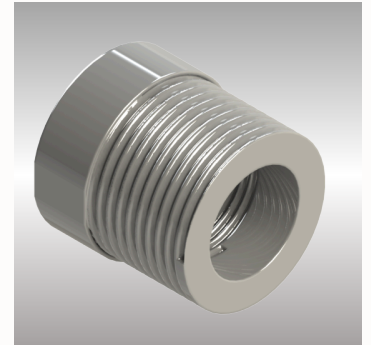

**Reducing Bush
Male & Female –
SS 304**

FPRB-4-27X21
33X21 / 48X33
48X21 / 60X48
60X33 / 60X21
73X60 / 73X48
73X33 / 73X21



**Double Nipple –
SS 304**

FPDN-4-21 / 33 / 48 /
60

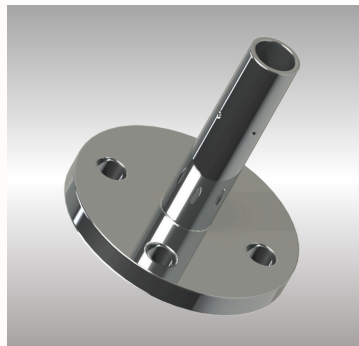

**F Table Flange
Adaptor - SS 304**

FPFAC-4-33 / 48
/ 60 / 73 / 90 / 114

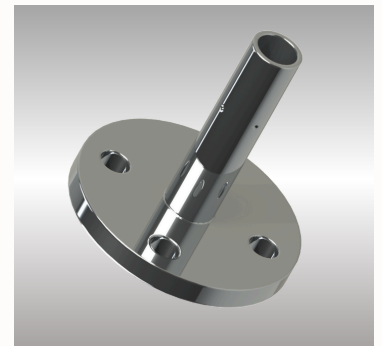

**F Table
Reducing Flange
Adaptor - SS 304**

FPRFAC-4-33X21
48X33,21/60X48,33,21
73X60,48,33/90X73,6
0,48/114X90,73,60

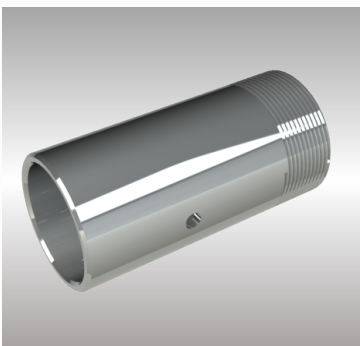

**Male Adapter –
SS 304**

FPMAC-4-21/ 33/ 48 /
60 / 73

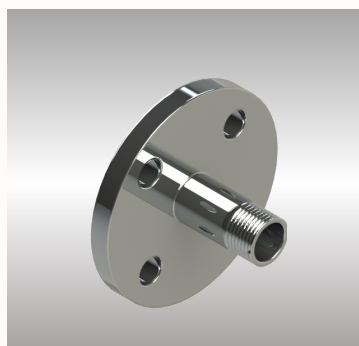

**F Table Threaded
Flange Adaptor -
SS 304**

FPTFA-4-33 / 40
/ 60 / 73 / 90 / 114



**F Table Reducing
Threaded Flange
Adaptor - SS 304**

FPTRFA-4-33X21
48X33,21/60X48,33,21
73X60,48,33/90X73,6
0,48/114X90,73,60

STANDARD ACCESSORIES



SS-304- One Piece Full Bore Female Threaded Ball Valve PN-16

FPBV-4-21 / 33 / 48 / 60

Aluminum / SS Butterfly Valve PN-16

FPBFV- 73 / 90 / 144

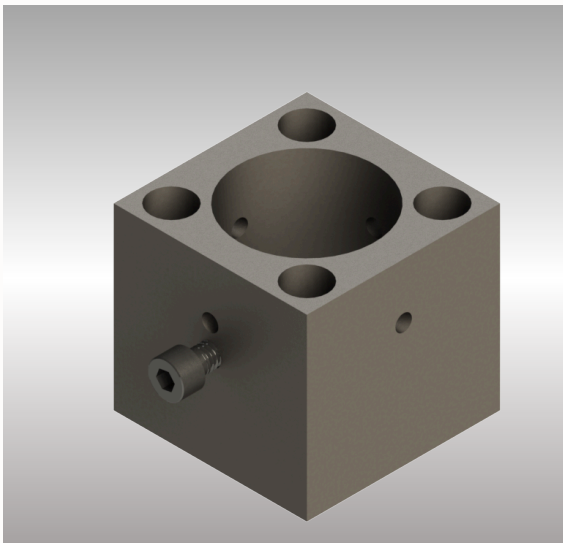

Set Of Drilling Fixtur

FPDF-21 / 33 / 48 / 60 / 73 / 90 / 114



Flexible R1 Hose

FPFH-21-1 / 33-1 /
48-1 / 60-1

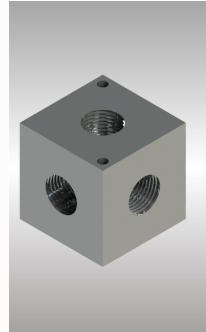

Manifold

FPM-4-21-1-3 / 6
FPM-4-33-1-3 / 6



Pipe Cutter

FPPCU 65 / 125



Pipe Clips

FPPC-21 / 33 / 48 /
60 / 73 / 90 / 114

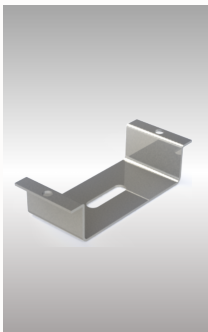

Wall Mounting Bracket

FPWMB-4X2 / 6X2

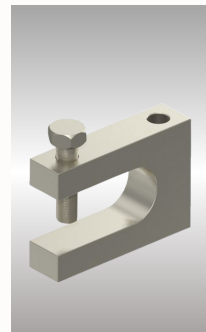

G Beam Clamp

FPGBC-20



Cantilever Support For Pipe

FPCSP-200 / -250 /
500

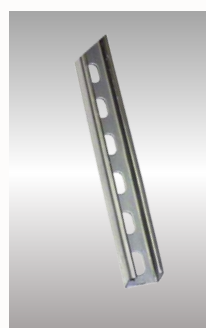

Slotted U- Channel

FPSUC-33X1

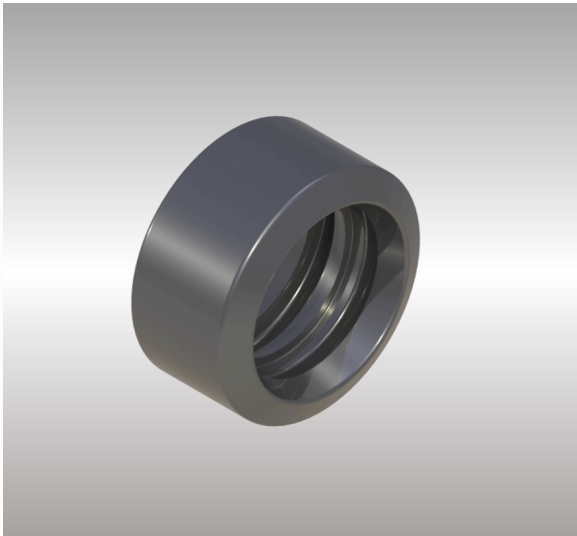

Main Seal Rubber-Coupling

FPCMSR-N-21 / 33 / 48 / 60 / 73 / 90 / 114

Flat Seal Ring

FPCFSR-N-21 / 33 / 48 / 60 / 73 / 90 / 114

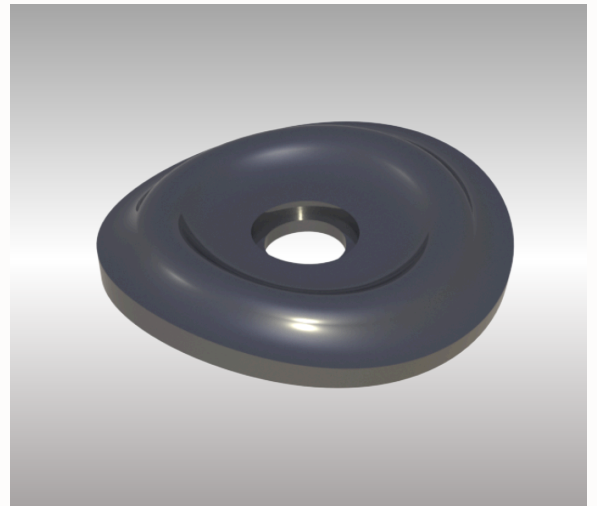

Seal Ring - Saddle Branch

FPDSR-N-33X21 / 48X33 / 60X33 / 73X48 / 90X60 / 114X73

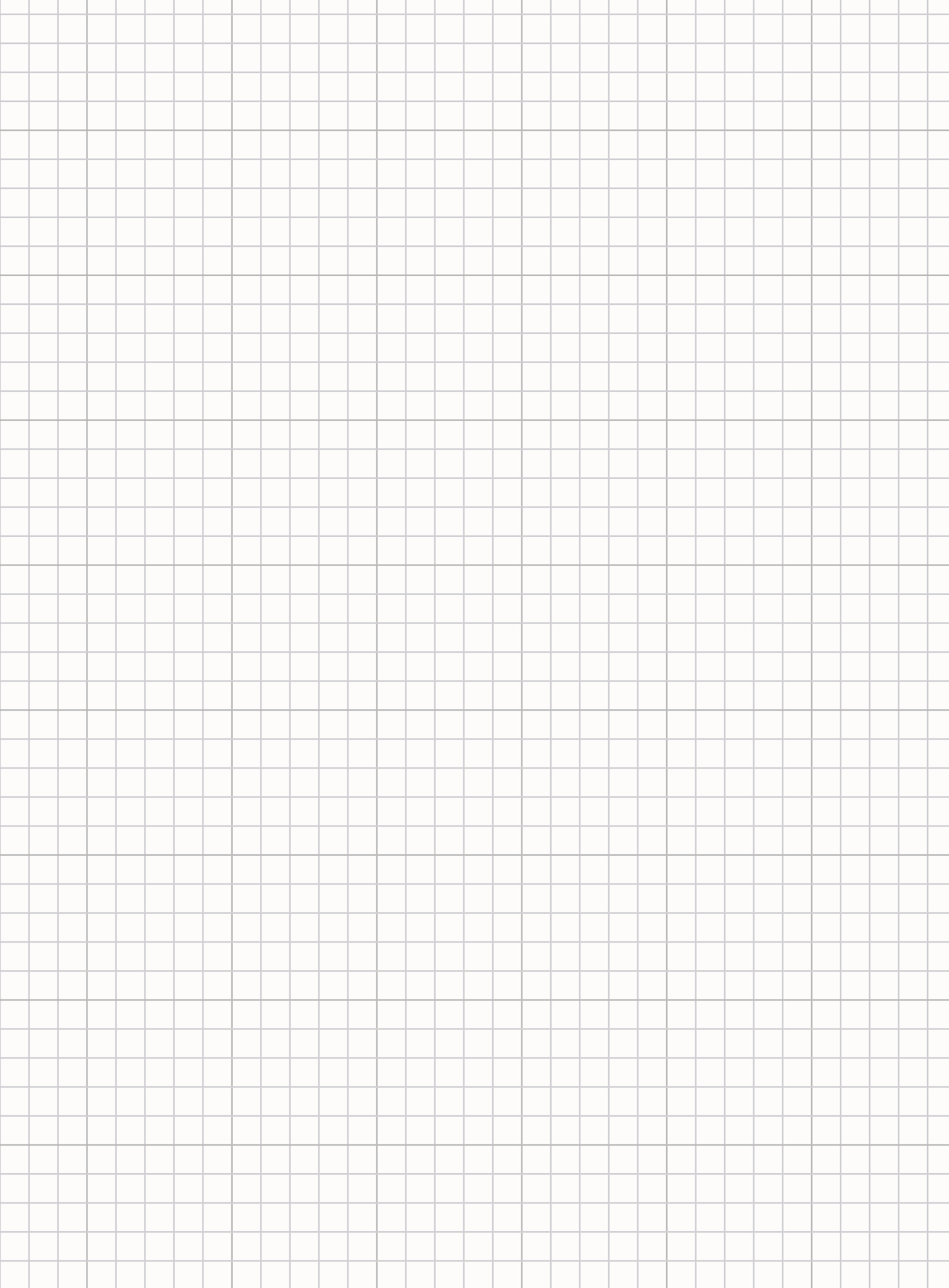



● **Register Office :**

Kimaya, Sr. No. 43/2/4, Gurukrupa
Colony Lane No. 2,
Wadachi Wadi Road, Opp. Rim's
International School,
Undri, Pune - 411 060.
Contact: +91 9372919096

● **Factory Add. :**

Sr. No. 36/1/5, Mantarwadi, Uruli
Devachi, Pune - 412 308.



Website: www.flowellpneumatics.in

E-mail: info@flowellpneumatics.in

* Specifications and descriptions here may change without notice.